

HKK55AA KAPPA LBP Compressor Top Efficiency R600a 220-240V 50Hz

General

Code number	CDO00039
Approvals	EN 60335-2-34 w. Annex AA
Compressors on pallet	100

Application

Application	LBP		
Frequency	Hz	50	60
Evaporating temperature	°C	-35 to -5	-
Voltage range	V	187 to 264	-
Max. condensing temperature continuous (short)	°C	60 (70)	-
Max. winding temperature continuous (short)	°C	130 (130)	-

Cooling requirements

Frequency	Hz	50			60		
Application		LBP	MBP	HBP	LBP	MBP	HBP
32°C		S	-	-	-	-	-
38°C		S	-	-	-	-	-
43°C		S	-	-	-	-	-
Remarks on application:							

Motor

Motor type	RSCR		
LRA (rated after 4 sec. UL984), HST LST	A	-	2.0
Cut in Current, HST LST	A	-	7.25
Resistance, main start winding (25°C)	Ω	40.6	24.8

Design

Displacement	cm ³	5.6
Oil quantity (type)	cm ³	165 (mineral)
Maximum refrigerant charge	g	150
Free gas volume in compressor	cm ³	1520
Weight without electrical equipment	kg	7.9

Dimensions

Height	mm	A	159
		B	165.5
Suction connector	location/I.D. mm angle	C	6.15 35°
	material comment		Copper Rubber plug
Process connector	location/O.D. mm angle	D	6.00 35°
	material comment		Copper Rubber plug
Discharge connector	location/I.D. mm angle	E	5.15 40°
	material comment		Copper Rubber plug
Oil cooler connector	location/I.D. mm angle	F	-
	material comment		-
Connector tolerance	I.D. mm		±0.05
Remarks on application:			

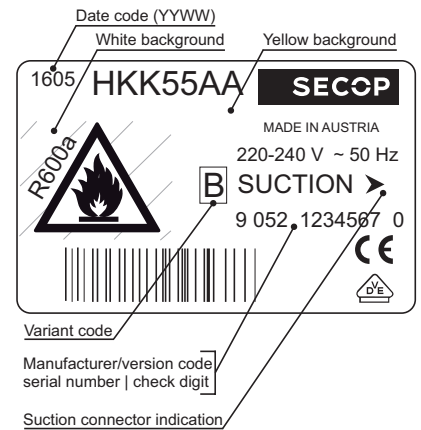

- S = Static cooling normally sufficient
- O = Oil cooling
- F₁ = Fan cooling 1.5 m/s (compressor compartment temperature equal to ambient temperature)
- F₂ = Fan cooling 3.0 m/s necessary
- SG = Suction gas cooling normally sufficient
- = not applicable in this area

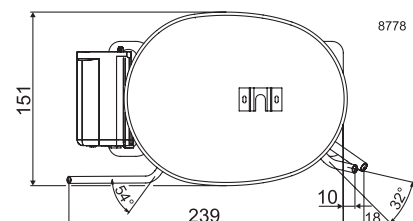
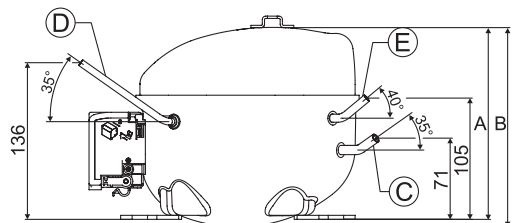
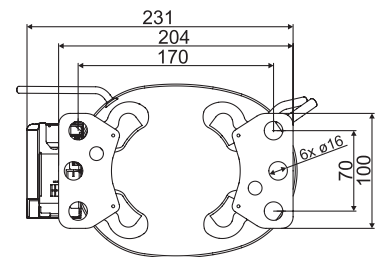

EN 12900 Household

220V, 50Hz, RC 2.5µF, PTC consumption incl., static cooling (alternative use of ePTC -1.4W)

Evap. temp. in °C	-45	-40	-35	-30	-25	-23.3	-20	-15	-10	-6.7	-5	0	5	7.2	10	15	20
Capacity in W			31.6	48.3	68.5	76.1	92.1	119	150	172	183						
Power cons. in W			34.9	43.2	51.6	54.4	60.0	68.6	77.2	82.9	85.8						
Current cons. in A			0.19	0.21	0.23	0.24	0.25	0.27	0.30	0.31	0.32						
COP in W/W			0.91	1.12	1.33	1.40	1.53	1.74	1.94	2.07	2.14						

ASHRAE LBP

220V, 50Hz, RC 2.5µF, PTC consumption incl., static cooling (alternative use of ePTC -1.4W)

Evap. temp. in °C	-45	-40	-35	-30	-25	-23.3	-20	-15	-10	-6.7	-5	0	5	7.2	10	15	20
Capacity in W			38.7	59.1	83.7	92.9	112	145	182	209	223						
Power cons. in W			34.8	43.0	51.3	54.2	59.7	68.2	76.7	82.3	85.2						
Current cons. in A			0.19	0.21	0.23	0.24	0.25	0.27	0.30	0.31	0.32						
COP in W/W			1.11	1.37	1.63	1.72	1.88	2.13	2.38	2.54	2.62						

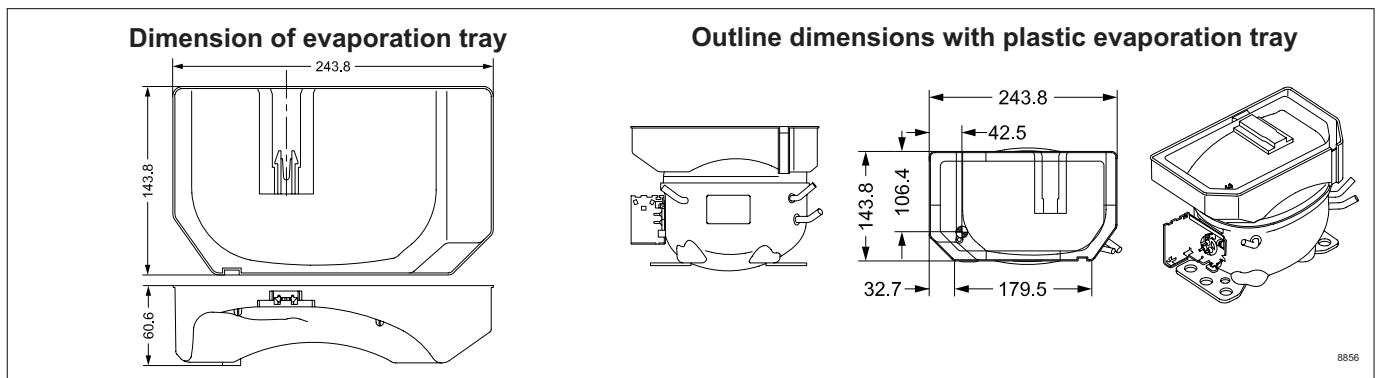
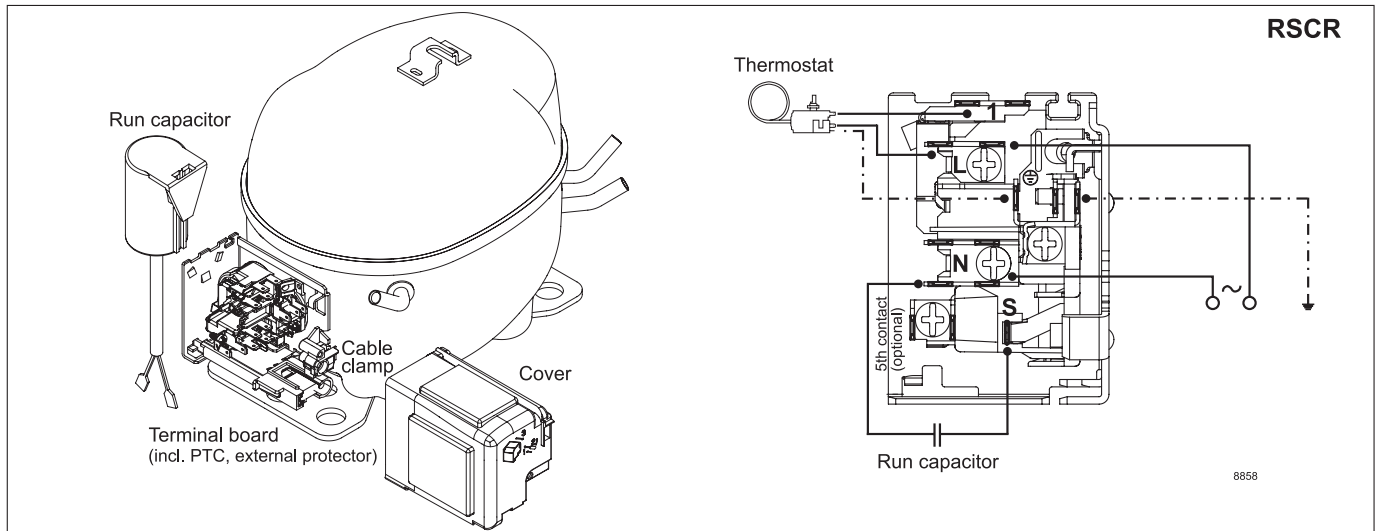

Accessories for	HKK55AA	Code number
Run capacitor (compulsory)	4.8 mm or 6.3 mm spade connectors	2.5 µF
Terminal board (incl. PTC and external protector)	4.8 mm or 6.3 mm spade connectors	ZHFF / DHFF
Motor Protector	AE 24 AHS x	FF
Cable clamp (screws not included)		113410_
Cover		157595_
Evaporation tray (optional)		113188_
All-in-one equipment, e.g. 4ZN		Code number
Cover / cable clamp + screws / earthing screw		16168000

Test conditions	EN 12900 Household	ASHRAE LBP
Condensing temperature	55°C	54.4°C
Ambient temperature	32°C	32°C
Suction gas temperature	32°C	32°C
Liquid temperature	no subcooling	32°C

Mounting accessories	Code number
on request, various options available	

Secop can accept no responsibility for possible errors in catalogues, brochures and other printed material. Secop reserves the right to alter its products without notice. This also applies to products already on order provided that such alterations can be made without consequential changes being necessary in specifications already agreed. All trademarks in this material are property of the respective companies. Secop and the Secop logotype are trademarks of Secop GmbH. All rights reserved. www.secop.com